

# LOW - COST TRANSISTORISED INTERCOM

PRADEEP G.

Several intercom circuits have appeared in EFY using integrated circuits. The circuit described here uses three easily available transistors only. Even a beginner can easily assemble it on a piece of veroboard.

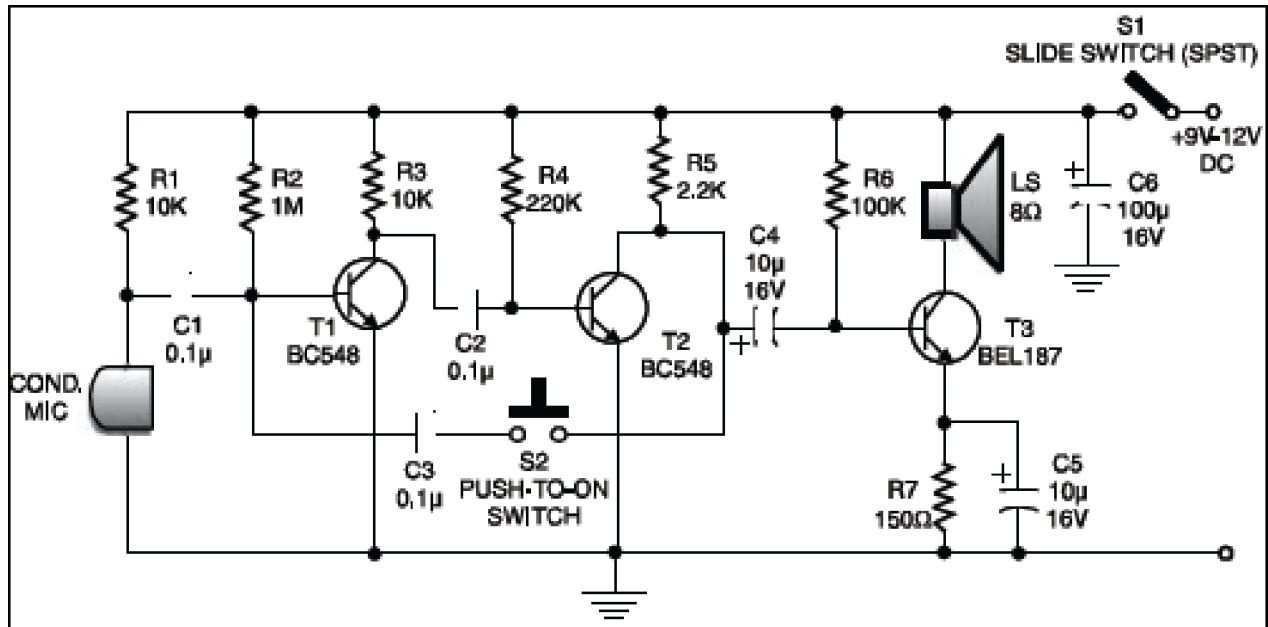

The circuit comprises a 3-stage resistor- capacitor coupled amplifier. When ring button S2 is pressed, the amplifier circuit formed around transistors T1 and T2 gets converted into an asymmetrical astable multivibrator generating ring signals. These ring signals are amplified by transistor T3 to drive the speaker of earpiece.

Current consumption of this intercom is 10 to 15 mA only. Thus a 9-volt PP3 battery would have a long life, when used in this circuit.

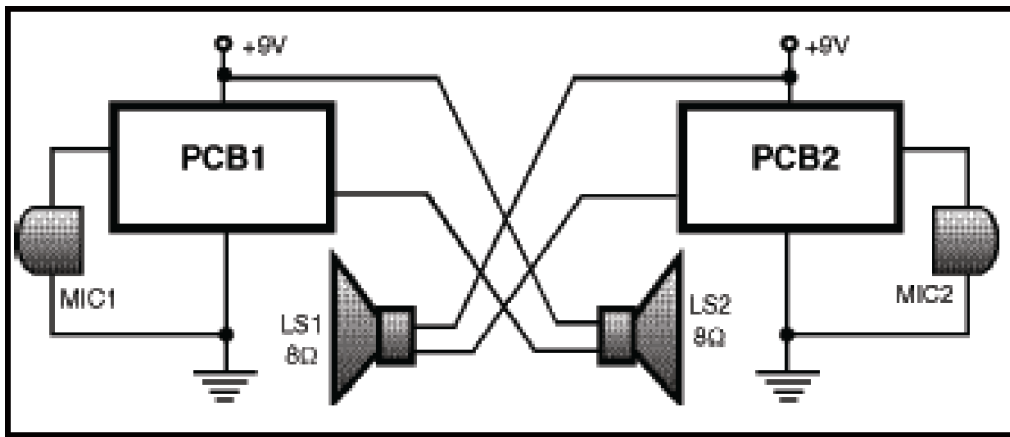

For making a two-way intercom, two identical units, as shown in figure, are required to be used. Output of one amplifier unit goes to speaker of the other unit, and vice versa. For single-battery operation, join corresponding supply and ground terminals of both the units together.

The complete circuit, along with microphone and earpiece etc, can be housed inside the plastic body of a toy cellphone, which is easily available in the market. Suggested cellphone cabinet, with the position of switches, speakers and mike etc is shown.

